

"TRADER" SERVICE SHEET
419

FERGUSON 802 AND 805 RADIOGRAM

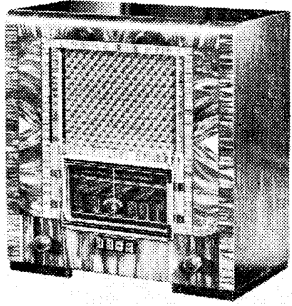

The Ferguson Model 802 AC/DC table receiver.

PRESS-BUTTONS for wave-change and gramophone switching are included in the Ferguson 802 6-valve (plus rectifier) 3-band superhet. The receiver is suitable for AC or DC mains of 200-250 V, and has a short-wave range of 16-50 m, a cathode-ray tuning

indicator and provision for both a gramophone pick-up and an extension speaker.

An identical chassis is fitted in the 805 radiogram, but this *Service Sheet* was prepared on a model 802.

Release date for both models: August, 1938.

CIRCUIT DESCRIPTION.

Aerial input is fed on MW and LW via series condenser **C1** to coupling condensers **C3**, **C4** via switch **S1**, that fraction of the signal voltage which is developed across **C4** being coupled to the tuning coils **L3** (MW) and **L4** (LW), which are tuned by **C33**. On SW, input is via **C1** and coupling condensers **C3**, **C5** to single tuned circuit **L2**, **C33**, **S1** then being open.

Resistance **R3** is connected between **V1** tetrode CG and **L3** to prevent the grid becoming free during the process of switching. **L1**, **R1** are included across the aerial circuit to suppress modulation hum.

First valve (**V1**, **6A8G**) is a heptode operating as frequency changer with electron coupling. Oscillator grid coils **L5** (SW), **L6** (MW) and **L7** (LW) are tuned by **C34**; parallel trimming by **C35** (SW), **C36** (MW) and **C8**, **C37** (LW);

series tracking by **C38** (SW), **C39** (MW) and **C40** (LW). Reaction by coils **L8** (SW), **L9** (MW) and direct coupling via **C9** (LW). **R8** is the oscillator CG resistance, but **R5** is connected directly between the CG and chassis to prevent the grid from becoming free during the process of switching.

Second valve (**V2**, **6U7G**) is a variable- μ RF pentode operating as intermediate frequency amplifier with tuned-primary tuned-secondary transformer couplings **C41**, **L10**, **L11**, **C42** and **C43**, **L12**, **L13**, **C44**.

Intermediate frequency 465 KC/S.

Diode second detector is part of double diode triode valve (**V3**, **6Q7G**), both diode anodes being strapped together. Audio frequency component in rectified output is developed across load resistance **R12** and passed via **IF** stopper **R13**, AF coupling condenser **C17**, manual volume control **R15** and further AF coupling condenser **C18**, to CG of triode section, which operates as AF amplifier. **IF** filtering by **C14**, **R13**, **C15** in diode circuit, **C19** in grid circuit and **C21** in anode circuit. Variable tone control by **C22**, **R19** in anode circuit. Provision for connection of pick-up across **C17**, **R15** via **S10**.

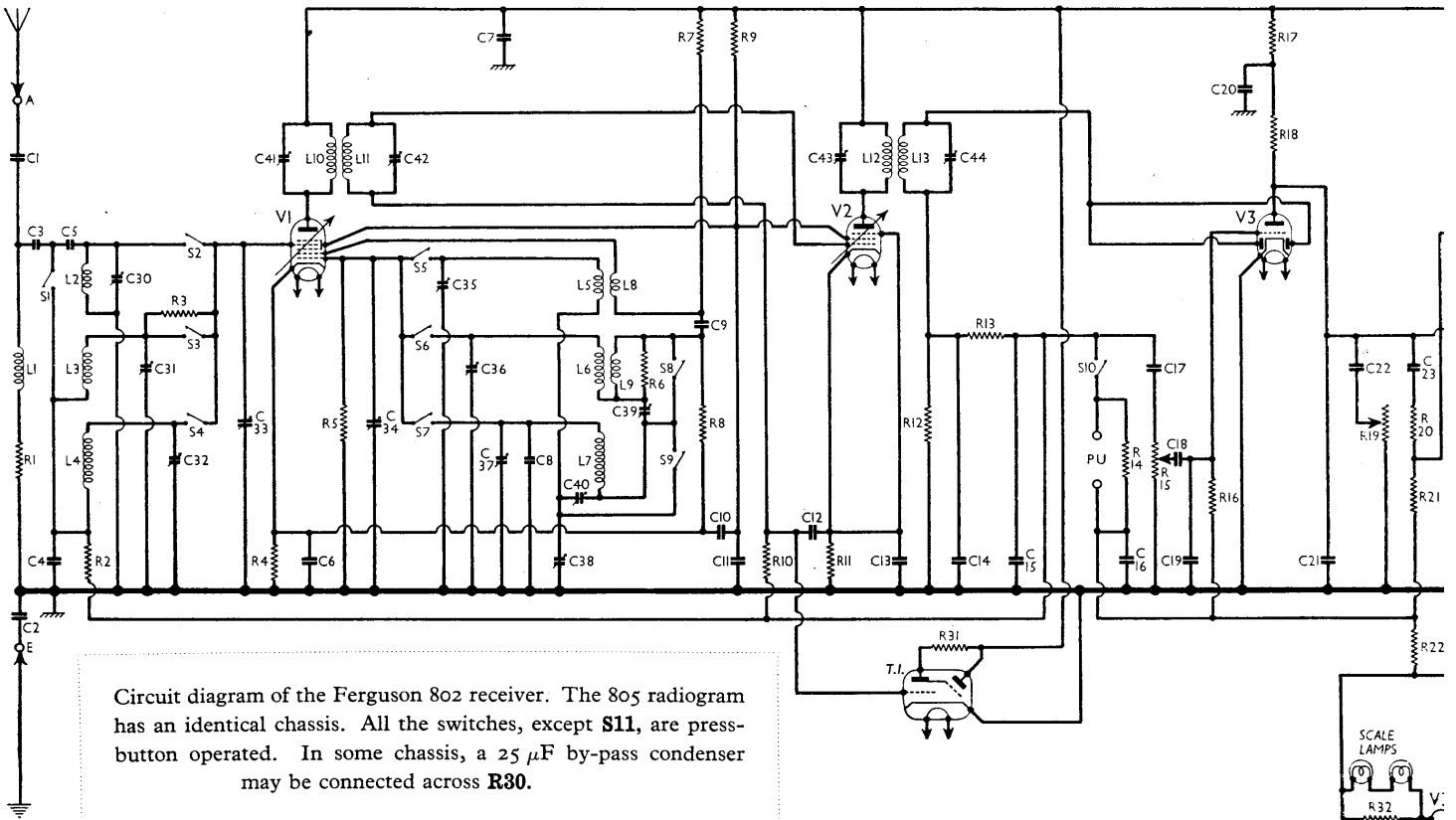

Circuit diagram of the Ferguson 802 receiver. The 805 radiogram has an identical chassis. All the switches, except **S11**, are press-button operated. In some chassis, a 25 μ F by-pass condenser may be connected across **R30**.

Under-chassis view. Diagrams of the press-button switch unit, which is indicated here, are shown in col. 6 overleaf, while the table (col. 5 overleaf) gives the action of the switches. **C35-C37** are visible in a row above the unit, while **C30-C32** are in a row beneath them. The trackers **C38-C40** are indicated here, but are adjusted through holes in the chassis deck.

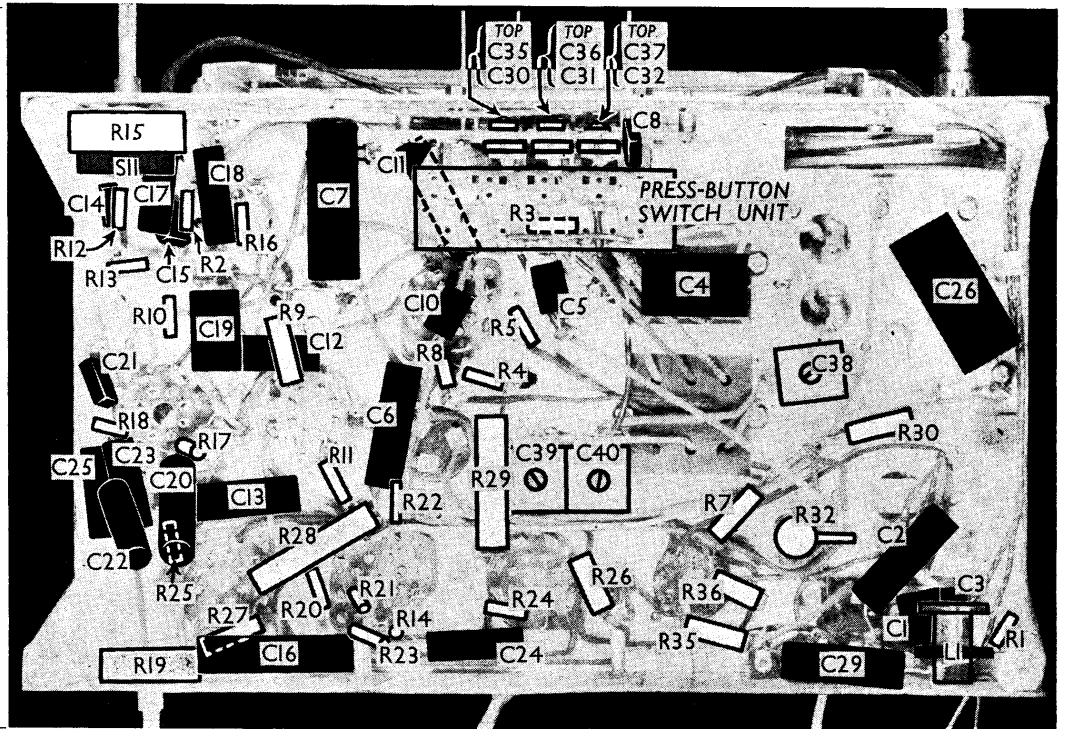

DC potential developed across **R12** is fed back through decoupling circuits as GB to FC (except on SW) and IF valves, giving automatic volume control. The AVC line potential, taken from the junction of **L11** and **R10**, is also applied to the

control grid of the cathode ray tuning indicator (**T.I.**, **6G5**) as control voltage.

Resistance-capacity coupling by **R18**, **C25** between **V3** triode and one side (**V6**) of push-pull output stage comprising two beam tetrode valves (**V5**, **V6**, **6V6G's**). The other side, **V5**, is fed via phase reversing valve (**V4**, **6C5G**) which obtains its input from junction of **R20**, **R21**, which form a step-down coupling to balance the valve gain. Provision is made for connection of high impedance external speaker between **V5**, **V6** anodes.

When the receiver is used with AC mains, HT current is supplied by IHC rectifying valve (**V7**, **25Z6G**) operating as half-wave rectifier which, on DC mains, behaves as a low resistance. Smoothing is effected by iron-cored choke **L15** and electrolytic condensers **C27** and **C28**.

Valve heaters are connected in series, together with scale lamps (with their shunt resistance **R32**) and ballast resistance, across mains input. Since scale lamp current is lower than that of the heaters of **V1**, **V2**, **V3**, **V4** and **T.I.**, **R32** by-passes the difference; and since the current of this series is lower than that of **V5** and **V6**, **R33** by-passes the difference in this case. **R34** by-passes a similar current value in the case of **V7** only.

DISMANTLING THE SET

Removing Chassis.—Remove the two control knobs and the four buttons (pull off) and the four bolts (each with two washers and a spring washer) holding the chassis to the bottom of the cabinet, when the chassis can be withdrawn to the extent of the speaker leads, which is sufficient for normal purposes.

When replacing, fit the buttons in the following order from left to right:—Gram, SW, MW, LW; see that the buttons

do not foul the escutcheon, and do not forget to replace the felt washers on the spindles of the rotary controls.

To free the chassis entirely, unsolder the speaker leads and when replacing, connect them as follows, numbering the tags on the speaker transformer (mounted above the speaker) from right to left, as marked on the insulating strip which carries the tags: 1, blue; 2, red from chassis and red from **L15** (mounted on left of speaker); 3, blue. The red lead with a white tracer coming from the chassis goes to the lower tag on **L15**.

Removing Speaker.—The speaker can be removed from the cabinet by unsoldering the leads and removing the nuts from the four screws holding it to the sub-baffle. When replacing, see that the transformer is at the top (with **L15** on the left) and connect the leads as indicated above.

VALVE ANALYSIS

Valve	Anode Voltage (V)	Anode Current (mA)	Screen Voltage (V)	Screen Current (mA)
V1 6A8G ..	{ 235 137	{ 5.2 3.0	96	3.5
Oscillator				
V2 6U7G ..	235	6.4	96	5.0
V3 6Q7G ..	93	0.35	—	—
V4 6C5G ..	47	0.8	—	—
V5 6V6G ..	224	23.0	235	1.0
V6 6V6G ..	224	23.0	235	1.0
V7 25Z6G†	—	—	—	—
T.I. 6G5 ..	{ 44 235	{ 0.6 1.7	—	—
Target				

† Cathode to chassis, 250 V, D.C.

Valve voltages and currents given in the table above are those measured in our receiver when it was operating on AC mains of 230 V, using the 220-230 V tapping on the mains transformer. The receiver was tuned to the lowest wavelength on the medium band and the volume

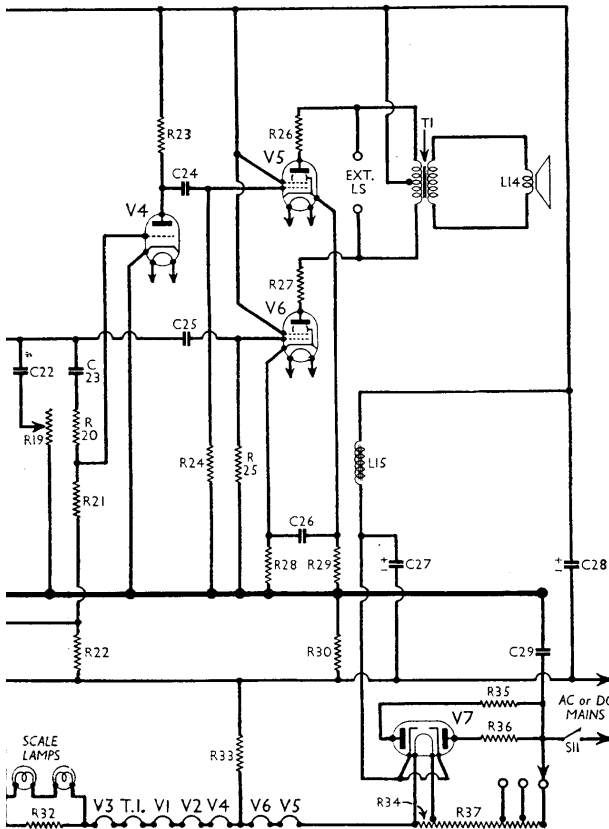

419 FERGUSON
802, 805

Supplement to *The Wireless & Electrical Trader*, August 5, 1939

control was at maximum. There was no signal input.

Voltages were measured on the 400 V scale of a model 7 Universal Avometer, chassis being negative.

COMPONENTS AND VALUES

RESISTANCES		Values (ohms)
R1	Anti-modulation choke damping	10,000
R2	V1 tetrode CG decoupling	500,000
R3	V1 tetrode CG resistance	3,000,000
R4	V1 fixed GB resistance	150
R5	V1 osc. CG resistance	500,000
R6	Osc. Circuit MW reaction damping	2,500
R7	V1 osc. anode HT feed resistance	25,000
R8	V1 osc. CG resistance	50,000
R9	V1, V2 SG's HT feed resistance	25,000
R10	V2 and T.I. CG's decoupling	500,000
R11	V2 fixed GB resistance	300
R12	V3 diodes load resistance	500,000
R13	IF stopper	25,000
R14	Gramophone PU shunt	25,000
R15	Manual volume control	500,000
R16	V3 triode CG resistance	500,000
R17	V3 triode anode HT feed	50,000
R18	V3 triode anode load	250,000
R19	Variable tone control	100,000
R20	V4 CG input pot. divider	500,000
R21	V4 CG input pot. divider	35,000
R22	V3 triode and V4 CG's decoupling	250,000
R23	V4 anode load resistance	250,000
R24	V5 CG resistance	500,000
R25	V6 CG resistance	500,000
R26	V5 anode RF stopper	100
R27	V6 anode RF stopper	100
R28	V6 GB resistance	600
R29	V5 GB resistance	600
R30	V3 triode and V4 auto GB resistance	25
R31	T.I. anode HT feed	250,000
R32	Scale lamps shunt	90
R33	Part heater circuit shunt	277
R34	V7 heater shunt	166
R35	V7 anode current limiting resistances	100
R36	V7 anode current limiting resistances	100
R37	Heater circuit ballast	380*

* 45 Ω ... 45 Ω × 290 Ω.

CONDENSERS		Values (μF)
C1	Aerial series condenser	0.0005
C2	Earth isolating condenser	0.1
C3	Aerial circuit MW and LW coupling potential divider	0.0001
C4	Aerial SW coupling condenser	0.0004
C5	V1 cathode by-pass	0.00002
C6	HT circuit RF by-pass	0.1
C7	Osc. circuit LW fixed trimmer	0.25
C8	V1 osc. anode coupling	0.00006
C9	V1, V2 SG's RF by-pass	0.00025
C10	V1, V2 SG's RF by-pass	0.00025
C11	V1, V2 SG's decoupling	0.1
C12	V2 CG decoupling	0.1
C13	V2 cathode by-pass	0.1
C14	IF by-pass condensers	0.00025
C15	IF by-pass condensers	0.00025
C16	V3 triode and V4 CG's decoupling	0.25
C17	AF coupling condensers to V3 triode	0.02
C18	V3 triode	0.02
C19	IF by-pass	0.0001
C20	V3 anode RF by-pass	0.1
C21	IF by-pass	0.00025
C22	Part of variable tone control	0.01
C23	V3 triode to V4 AF coupling	0.01
C24	V4 to V5 AF coupling	0.01
C25	V3 triode to V6 AF coupling	0.01
C26	V5, V6 cathodes by-pass	1.0
C27*	HT smoothing	16.0
C28*	HT smoothing	16.0
C29	Mains RF by-pass	0.1
C30†	Aerial SW trimmer	—
C31†	Aerial circuit MW trimmer	—
C32†	Aerial circuit LW trimmer	—
C33†	Aerial circuit tuning	—
C34†	Oscillator circuit tuning	—
C35†	Osc. circuit SW trimmer	—
C36†	Osc. circuit MW trimmer	—
C37†	Osc. circuit LW trimmer	—
C38†	Osc. circuit SW tracker	—
C39†	Osc. circuit MW tracker	—
C40†	Osc. circuit LW tracker	—
C41†	1st IF trans. pri. tuning	—
C42†	1st IF trans. sec. tuning	—
C43†	2nd IF trans. pri. tuning	—
C44†	2nd IF trans. sec. tuning	—

* Electrolytic. † Variable. ‡ Pre-set.

OTHER COMPONENTS		Approx. Values (ohms)
L1	Aerial anti-modulation choke	20.0
L2	Aerial circuit SW tuning coil	0.1
L3	Aerial circuit MW tuning coil	3.0
L4	Aerial circuit LW tuning coil	17.0
L5	Osc. circuit SW tuning coil	0.1
L6	Osc. circuit MW tuning coil	3.0
L7	Osc. circuit LW tuning coil	5.9
L8	Oscillator SW reaction coil	0.5
L9	Oscillator MW reaction coil	1.0
L10	1st IF trans. Pri.	9.0
L11	1st IF trans. Sec.	11.0
L12	2nd IF trans. Pri.	12.0
L13	2nd IF trans. Sec.	9.0
L14	Speaker speech coil	2.0
L15	HT smoothing choke	230.0
T1	Speaker in. Pri., total put trans.	660.0
T1	Speaker in. Sec.	0.5
S1-S9	Waveband switches	—
S10	Gram. pick-up switch	—
S11	Mains switch, ganged R15	—

GENERAL NOTES

Switches.—All the switches, with the exception of **S11**, the mains switch, are of the press-button type, and are contained in a single double-sided unit mounted inside the front of the chassis.

The switch unit is indicated in our underchassis view, but for identification of the individual switches the diagrams in col. 6 must be consulted. The upper diagram of the two shows the switches seen when looking at the underside of the chassis, while the lower one shows the switches on the unit which are normally hidden from view by the chassis deck.

To examine these, the whole switch unit must be removed. To do this, remove

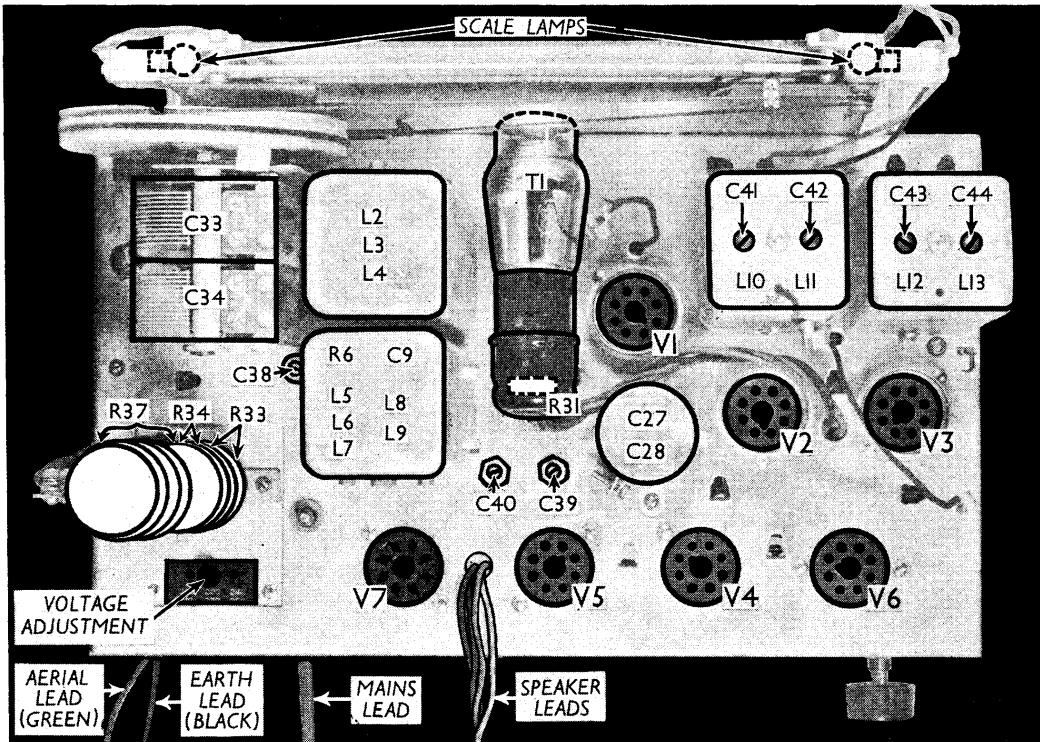

Plan view of the chassis. The adjustment screws of the trackers **C38**, **C39** and **C40** are indicated here, as are also the IF trimmers. **R33**, **R34** and **R37** form a single unit, in which **R34** and **R37** are connected in series as shown in the circuit diagram. **R33**, which is terminated at the bottom pair of terminals, is isolated from **R34**, **R37**.

the screws holding the two banks of three trimmers (above and below the switch unit) and the two screws holding the unit to the chassis and gently ease the unit out, taking care not to break any connections.

The table (col. 5) gives the switches which are closed and open when each button is depressed.

S11 is the QMB mains switch, ganged with the volume control **R15**.

Coils.—**L1** is beneath the chassis, close to the aerial lead entry point. **L2-L4**; **L5-L9** and the IF transformers **L10, L11** and **L12, L13** are in four screened units on the chassis deck. The second unit also contains **R6, C9**, while the IF units contain their associated trimmers.

Scale Lamps.—These are two National Union miniature bayonet cap types, marked N51. The rating is presumably 6.9 V, 0.3 A.

External Speaker.—Two sockets are provided at the rear of the chassis for a high impedance (10,000 Ω) speaker.

Condensers C27, C28.—These are two dry electrolytics in a single tubular metal case on the chassis deck. Beneath the chassis there are three tags. The plain one is the common negative; those spotted red are the positive of **C27** (16 μ F) and the positive of **C28** (also 16 μ F).

Trimmers.—The aerial circuit trimmers (**C30-C32**) are in a row below the press-button switch unit (looking from the underside of the chassis), while the oscillator circuit trimmers (**C35-C37**) are in a similar row above the switch unit. All six trimmers are adjustable through holes in the front of the chassis.

Trackers.—The three variable trackers (**C38-C40**) are mounted beneath the chassis, and are adjustable through holes in the chassis deck.

Resistors R33, R34, R37.—These are in a tubular vitreous enamelled unit, mounted vertically on the chassis deck. Reference to the circuit diagram will show their connections, from which it will be seen that **R34** and **R37** are in series, whereas **R33** is isolated.

Starting from the top of the unit, the first three tags are the end and tappings of **R37**, the fourth tag is the junction of **R37** and **R34**, the fifth is the other end of **R34**, and the sixth and seventh are the ends of **R33**.

Resistor R31.—This is inside the connector socket of the tuning indicator.

Chassis Divergencies.—**C8** and **R8** are

TABLE AND DIAGRAMS OF THE SWITCH UNIT

Button	Closed	Open
LW	S1, S4, S7, S8	S2, S3, S5, S6, S9, S10
MW	S1, S3, S6, S9	S2, S4, S5, S7, S8, S10
SW	S2, S5, S8, S9	S1, S3, S4, S6, S7, S10
Gram.	S1, S8, S9, S10	S2, S3, S4, S5, S6, S7

not shown in the makers' diagram. A 25 μ F electrolytic by-pass condenser is shown connected across **R30**, the auto GB resistance, in the makers' diagram, as is also a second 0.00025 μ F IF by-pass condenser in addition to **C21** in **V3** triode anode circuit.

Another difference, which may be found in some chassis, is that whereas we show two independent GB resistances **R28** and **R29** in **V5, V6** cathodes circuits, with a condenser linking the cathodes, the cathodes may be joined directly together and lead via a single 300 Ω resistance to chassis. In this case, the by-pass condenser may be 5 μ F electrolytic, and form part of a dual condenser block. The second condenser of the block would then be connected across **R30** as suggested above.

There was also a difference between the heater sequence in our chassis and that the makers' diagram. Their sequence was as follows, starting from the high potential end: **V7, V6, V5, T.L., V2, V4, V1, V3**.

RADIOGRAM 805 MODIFICATIONS

The only difference in the 805 radiogram (apart from the inclusion of a 2,000 Ω pick-up and a motor) is that the speaker is a 10-in. model, instead of the 8-in. model used in the 802. Its resistance values remain the same.

CIRCUIT ALIGNMENT

IF Stages.—Remove the grid (top cap) connection of **V1**, and connect a 0.5 MO resistor between the connection and the cap. Connect signal generator between the cap (via a 0.00025 μ F condenser) and chassis. Switch set to MW, and turn gang and volume control to maximum.

Feed in a 465 KC/S signal, and adjust **C44, C43, C42** and **C41** for maximum output. Re-check, then remove the 0.5 MO resistor and replace top cap.

RF and Oscillator Stages.—With the gang at maximum, pointer should be at the right hand terminations of the horizontal scales. Connect signal generator to **A** and **E** leads, via a suitable dummy aerial. Turn volume control to maximum.

SW.—Since the SW tracker is in series

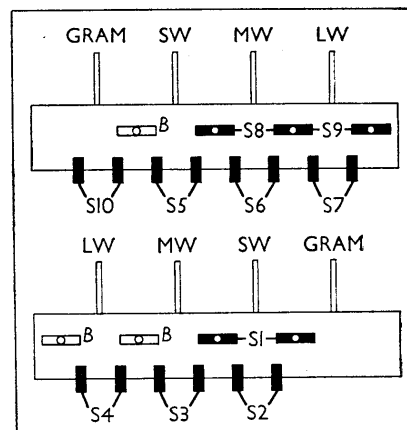

Diagrams of both sides of the switch unit. The upper one shows the switches seen from the underside of the chassis, while the lower one shows those on the side nearer the chassis deck.

with the MW and LW trackers it is essential to align the SW band first.

Switch set to SW, tune to 15 MC/S on scale, and feed in a 15 MC/S (20 m) signal. Adjust **C35** for maximum output, using the peak involving the least trimmer capacity. Now adjust **C30** for maximum.

Feed in a 6 MC/S (50 m) signal, tune it in, and adjust **C38** for maximum output, while rocking the gang for optimum results. Return to 15 MC/S and re-check **C30** and **C35**. Repeat until no further improvement results.

MW.—Switch set to MW and tune to 250 m on scale. Feed in a 250 m (1,200 KC/S) signal, and adjust **C36**, then **C31** for maximum output. Feed in a 520 m (580 KC/S) signal, tune it in, and adjust **C39** for maximum output, while rocking the gang for optimum results. Return to 250 m and re-check **C36** and **C31**. Repeat until no further improvement results.

LW.—Switch set to LW, and tune to 1,250 m on scale. Feed in a 1,250 m (240 KC/S) signal and adjust **C37**, then **C32**, for maximum output. Feed in a 2,000 m (150 KC/S) signal, tune it in, and adjust **C40** for maximum output, while rocking the gang for optimum results. Return to 1,250 m and re-check **C37** and **C32**. Repeat until no further improvement results.

S A T O R

POTENTIOMETERS

FOR SILENT SERVICE

SEE THIS ISSUE RADIO MAINTENANCE

REPLACEMENT FOR
FERGUSON 802

VOLUME CONTROL KBP 31055 (.5 Meg)
TONE CONTROL TYPE KBP 30015 (.1 Meg)

LIST PRICE 3/- without Switch, 4/- with Switch
SERVICE ENGINEERS 50% DISCOUNT

ORION LAMPS LTD., 82/4 Theobalds Rd., W.C.1
Telephone—HOLBORN 9150 HEAD FACTORIES IN AUSTRIA